

Usable only for Hpe_IRP2

General Description:

The HC-PCIeX1hs is a high speed child board. This means up to 10 LVDS pairs are connected directly to the FPGA SERDES.

On this child board is a PCI Express X4 over cable connector. There are 2 population options available, depending on the developer's requirement.

-d option: downstream board

Root complex in PC

-u option: upstream board

Root complex in Hpe_IRP2



Sorry the population option can be done only during manufacturing.

Block diagram:

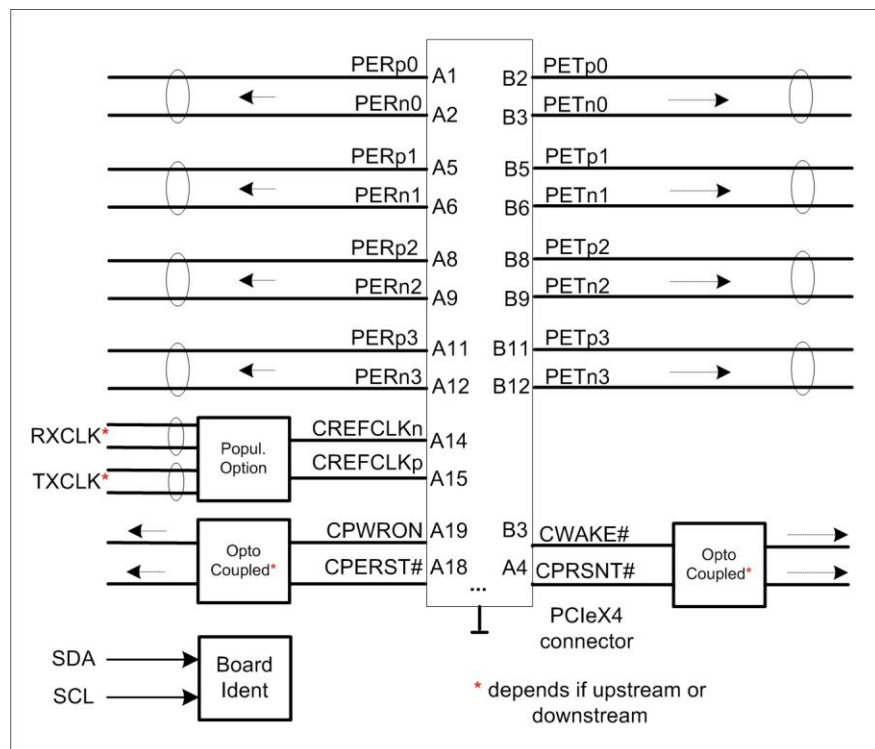

Pin description:

A1	GND	A2	GND	B1	X1B_WAKE_TX	B2	X1B_WAKE_RX#
A3	RX_DATA0+	A4	GND	B3	X1B_PWRGD_TX	B4	X1B_PWRGD_RX#
A5	RX_DATA0-	A6	GND	B5	X1B_RESET_TX#	B6	X1B_RESET_RX
A7	GND	A8	GND	B7	X1B_PWRON_TX	B8	X1B_PWRON_RX#
A9	TX_DATA0+	A10	GND	B9	NC	B10	NC
A11	TX_DATA0-	A12	GND	B11	NC	B12	NC
A13	GND	A14	GND	B13	NC	B14	NC
A15	RX_DATA1+	A16	GND	B15	VCC3V3	B16	GND
A17	RX_DATA1-	A18	GND	B17	VCC3V3	B18	GND
A19	GND	A20	GND	B19	VCC3V3	B20	GND
A21	TX_DATA1+	A22	GND	B21	VCC3V3	B22	GND
A23	TX_DATA1-	A24	GND	B23	VCC3V3	B24	GND
A25	GND	A26	GND	B25	VCC3V3	B26	GND
A27	RX_CLK+	A28	GND	B27	VCC3V3	B28	GND
A29	RX_CLK-	A30	GND	B29	VCC3V3	B30	GND
A31	GND	A32	GND	B31	NC	B32	I2C_SCL
A33	GND	A34	GND	B33	NC	B34	GND
A35	TX_CLK+	A36	GND	B35	NC	B36	I2C_SDA
A37	TX_CLK-	A38	GND	B37	V12V0 - NC	B38	GND
A39	GND	A40	GND	B39	V12V0 - NC	B40	GND
A41	GND	A42	GND	B41	V12V0 - NC	B42	GND
A43	RX_DATA2+	A44	GND	B43	V12V0 - NC	B44	GND
A45	RX_DATA2-	A46	GND	B45	V12V0 - NC	B46	GND
A47	GND	A48	GND	B47	V12V0 - NC	B48	GND
A49	TX_DATA2+	A50	GND	B49	V12V0 - NC	B50	GND
A51	TX_DATA2-	A52	GND	B51	V12V0 - NC	B52	GND
A53	GND	A54	GND	B53	NC	B54	NC
A55	RX_DATA3+	A56	GND	B55	X1B_BOARD_TP1	B56	X1B_BOARD_TP7
A57	RX_DATA3-	A58	GND	B57	X1B_BOARD_TP2	B58	X1B_BOARD_TP8
A59	GND	A60	GND	B59	X1B_BOARD_TP3	B60	NC
A61	TX_DATA3+	A62	GND	B61	X1B_BOARD_TP4	B62	NC
A63	TX_DATA3-	A64	GND	B63	X1B_BOARD_TP5	B64	NC
A65	GND	A66	GND	B65	X1B_BOARD_TP6	B66	NC

Copyright Notice

This document is copyrighted 2011 by Gleichmann Electronics Research (Austria) GmbH & Co KG. All rights are reserved. Gleichmann Electronics Research (Austria) GmbH & Co KG reserves the right to make improvements to the products described in this manual at any time without notice. No part of this data sheet may be reproduced, copied, translated or transmitted in any form or by any means without the prior written permission of GE Research.